



## TANKS FOR CARTRIDGE FILTERS

### DOMINO TANK

# DOMINO - DM70

## With Pilot Group

*New concept of cascade cleaning in cartridges filters*



New concept of cascade cleaning in cartridges filters. Very silent solution, flexibility in storage, modularity on different kind of electronic control.

General costs reduction of external tanks, bulkhead connection, holes in the filter's wall, cabling and blow tubes inside the filter.



### PRODUCT CERTIFICATIONS

STANDARD



OPZIONALI



### VALVE TECHNICAL FEATURES

Features		Values
Out		OUT 1"
Working Pressure		1,5-7Bar (Max)
Standard Temperature Range		-10 C° +50C°
Weight		4,6kg
Protection Level		IP65
Air quality classes ( ISO 8573-1)	For Solid	2
	For Water with T > +3°C	4
	For Water with -20°C < T < +3°C	3
	For Water with -40°C < T < -20°C	2
	For Oil	1



### PARTS LIST

No.	Description	Material
1	Screw M6	SS
2	Washer Grover M6	SS
3	Cover 1"	Die Cast Alu
4	Spring 1"	SS
5	Membrane 1"	TPU
6	Valve 1"	Die Cast Alu
7	Tank	CS
8	1/4"-6/8"-8/10" Fitting	

Immagine

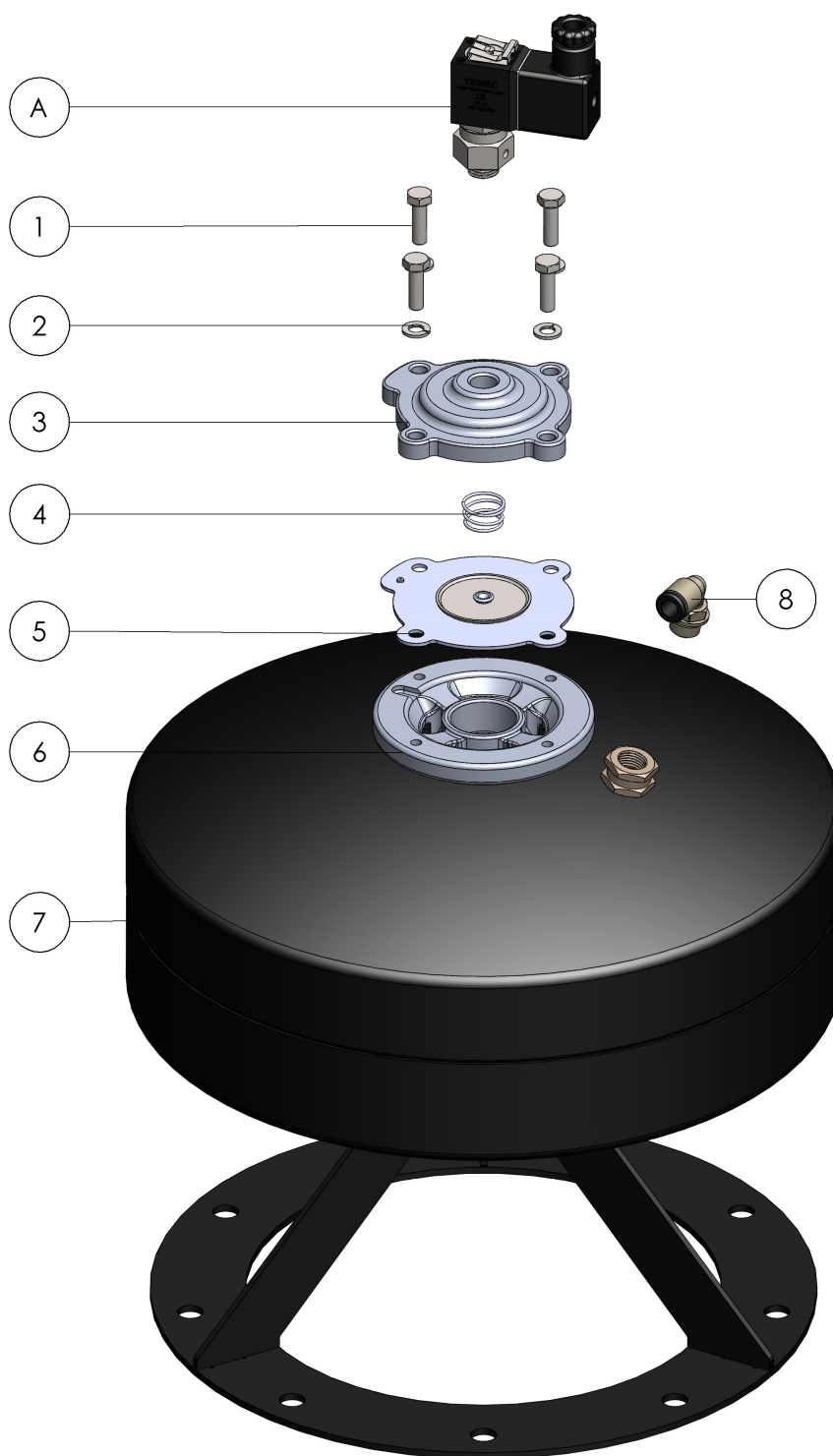



DIMENSIONAL LAYOUT

